

VICTORY SWEEPERS INC.

WINNING TOGETHER

TM



8 hours on 1.5 gallons

Oh yes it will !!

The T500, exclusively from Victory Sweepers

← T500

*Actual results may vary. Estimate is based on a U.S. gallon of gasoline. Truck chassis not included. Sweeper powered by a 5.5 horsepower Honda engine. Test chassis is 2007 Toyota Tacoma, 4 cylinder, gasoline engine that consumed approximately 4 gallons in 8 hours during the test. Pretty impressive, huh? Yeah... we thought so too.

866.50.SWEEP

866.507.9337



Optional Stainless Steel T500

victorysweepers.com

VICTORY SWEEPERS, INC. • 9584 MADISON BLVD • MADISON • AL • 35758

T 500 SPECIFICATIONS



Frame	2"x2"x 1/4" Wall Square Steel Tubing
Axle Capacity.....	2000 lbs
Tires.....	20.5 x 8-10
Payload.....	1000 lbs
Paint	Powder Coated <i>(Black Frame w/ your choice of high visibility Blue or Green Body colors, Optional unpainted stainless steel also available)</i>
Hopper.....	16 gauge steel
Hopper Coating	Powder Coated inside & out
Hopper Capacity.....	1.5 cu yds (volumetric)
Engine	Honda 5.5 Horsepower
Power Head.....	Width 48"
Hydraulic Curb Broom	Width 22"
Overall Length.....	132"
Overall Width.....	82"/1,778mm <i>(includes curb broom)</i>
Overall Height.....	49"
Total Dry Weight	998 Lbs
Optional Dust Control	25 Gal, 12v dc
Warranty	One Year Limited

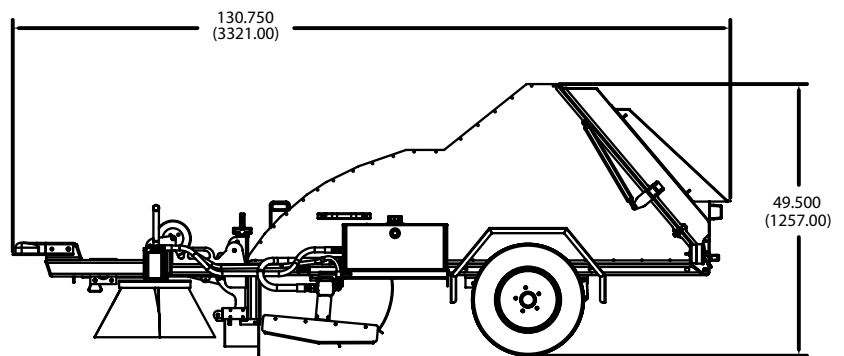
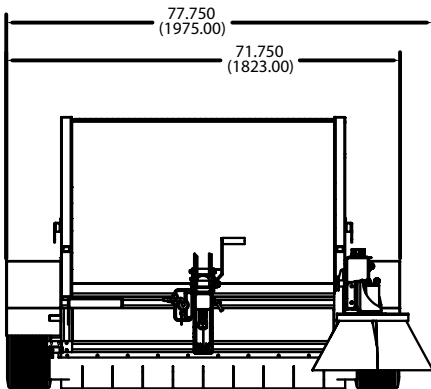

**Specifications subject to change without notice.*